AVR042: AVR Hardware Design Considerations

Features

- Providing robust supply voltage, digital and analog.
- Connection of RESET line.
- SPI interface for In-System Programming.
- Using external crystal or ceramic resonator oscillators.

1 Introduction

This application note has been written to provide answers to some of the questions and problems faced when starting designs involving AVR microcontrollers. The application note treats topics that are known to cause problems. The scope is to provide an introduction to potential design problems rather than being an exhaustive walk-through of how to design applications using the AVR microcontrollers. This document is thus a collection of information from existing Atmel AVR documents, combined with information that is not previously documented.

It is highly recommended to read the application note AVR040 - "EMC Design Considerations" – before initiating a new design, specially if the aim of the design is a commercial application that needs to meet the requirements of the EMC directive (or similar directives in countries outside Europe). The application note is available from the AVR section of the official Atmel website <http://www.atmel.com>.



8-bit **AVR**[®]
Microcontrollers

Application Note

Rev.2521C-AVR-09/05



2 Power Supply

Two aspects should be considered when designing the power supply for the discrete/digital elements of an AVR; ESD protection and noise emission. Both these topics are treated in details in the AVR040 application note, and only a short summary is included in this document.

2.1 Digital supply

Looking at the datasheet for an AVR microcontroller, one can be fooled to believe that power supply is not critical. The device has a very wide voltage range, and draws only a few mA supply current. But as with all digital circuits, the supply current is an average value. The current is drawn in very short spikes on the clock edges, and if I/O lines are switching, the spikes will be even higher. The current pulses on the power supply lines can be several hundred mA if all eight I/O lines of an I/O port changes value at the same time. If the I/O lines are not loaded, the pulse will only be a few ns.

This kind of current spike cannot be delivered over long power supply lines; the main source is (or should be) the decoupling capacitor.

Figure 2-1. Incorrect decoupling

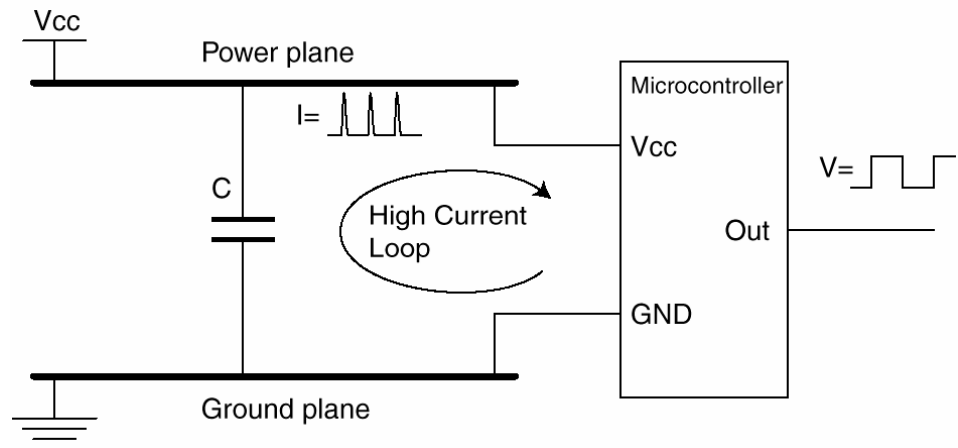
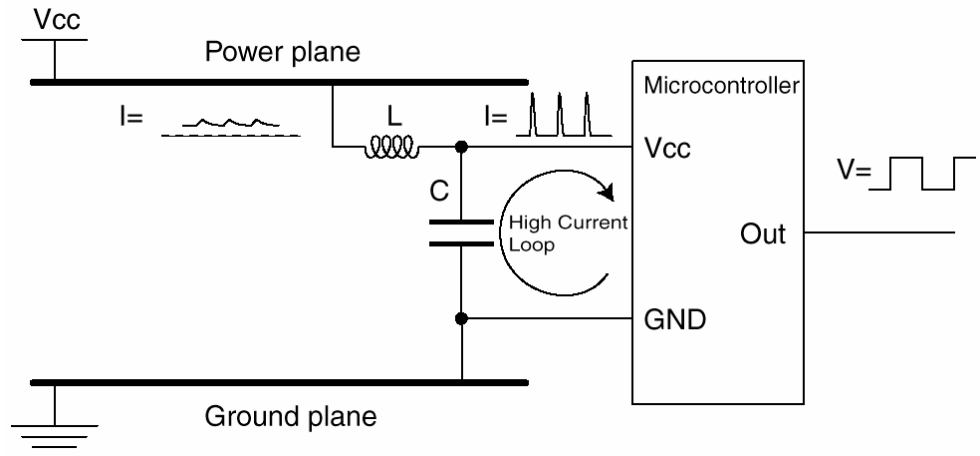

Figure 2-1 shows an example of insufficient decoupling. The capacitor is placed too far away from the microcontroller, creating a large high current loop. The power and ground planes here are parts of the high current loop. As a result of this, noise is spread more easily to other devices on the board, and radiated emission from the board is increased even further. The whole ground plane will act as an antenna for the noise, instead of only the high current loop. This will be the case if the power and ground pins are connected directly to the planes (typical for hole-mounted components) and the decoupling capacitor is connected the same way. The same is often seen for boards with surface-mount components if the integrated circuits are placed on one side of the board and the decoupling capacitors are placed on the other.

Figure 2-2 shows a better placement of the capacitor. The lines that are part of the high current loop are not part of the power or ground planes. This is important, as the

power and ground planes otherwise will spread a lot of noise. Further, the figure shows another improvement of the decoupling. A series inductor is inserted to reduce the switching noise on the power plane. The series resistance of the inductor must of course be low enough to ensure that there will be no significant DC voltage drop.

Figure 2-2. Decoupling with series inductor.



Generally, the AVR devices where power and ground lines are placed close together (like the ATmega8535) will get better decoupling than devices with industry standard pin-out (like the ATmega8515), where the power and ground pins are placed in opposite corners of the DIP package. This disadvantage can be overcome by using for example a TQFP package, which allows decoupling capacitors to be placed very close to the die. For devices with multiple pairs of power and ground pins, it is essential that every pair of pins get its own decoupling capacitor.

The main supply should also have a tantalum capacitor of some μF to stabilize it.

2.2 Analog supply

The AVR devices that have built-in ADC have a separate analog supply voltage pin, AVcc. This separate voltage supply is provided to make the analog circuits less prone to the digital noise originating from the switching of the digital circuits. The analog ground, AGND, is also separated from the digital ground, - for the same reasons.

To be able to obtain good accuracy with the ADC the analog supply voltage must be decoupled separately, in the same manor as the digital supply voltage. The analog ground should be separated from the digital ground, - so that the analog and digital ground are only connected at one point, - the origin of the GND i.e. at the power supply GND.

3 Connection of RESET pin on AVRs

The RESET pin on the AVR is active LOW, and setting the pin LOW externally will thus result in a reset of the AVR. The RESET has two purposes:

1. To release all lines by tri-stating all pins (except XTAL pins), initialize all I/O registers and set program counter to zero.



2. To enter programming mode (for some parts also the PEN line is used to enter programming mode). Furthermore it is possible to enter high-voltage/parallel programming mode by drawing the RESET pin "very" high, where very high means 11.5 – 12.5V (refer to the datasheet of the device for more information).

The reset line has an internal pull-up resistor, but if the environment is noisy it can be insufficient and reset can therefore occur sporadically. Refer to datasheet for value of pull-up resistor on specific devices.

Different approaches can be used to connect the RESET pin so that unintentional reset of the AVR is avoided. External brown-out or supervisory circuit can be used to control the RESET pin. If an external brown-out circuit, like the ones described in application note AVR180, is applied one would not need to consider how to connect the RESET pin further. However, if the AVR device used in the application has built-in brown-out circuit, the external brown-out can be saved and a more simple solution can be chosen to control the state of the RESET pin.

Connecting the RESET so that it is possible to enter both high-voltage programming and ordinary low level reset can be achieved by applying a pull-up resistor to the RESET line. This pull-up resistor makes sure that reset does not go low unintended. The pull-up resistor can in theory be of any size, but if the AVR should be programmed from e.g. STK500/AVRISP the pull-up should not be so strong that the programmer cannot activate RESET by draw the RESET line low. The recommended pull-up resistor is 4.7kOhm or larger when using STK500 for programming.

To protect the RESET line further from noise, it is an advantage to connect a capacitor from the RESET pin to ground. This is not directly required since the AVR internally have a low-pass filter to eliminate spikes and noise that could cause reset. Applying an extra capacitor is thus an additional protection. If not using High Voltage Programming it is recommended to add an ESD protecting diode from RESET to Vcc, since this is not internally provided due to High Voltage Programming. The components should be located physically close to the RESET pin of the AVR. Figure 3-1 shows the recommended circuit on the RESET line.

Figure 3-1. Recommended Reset Pin connection.

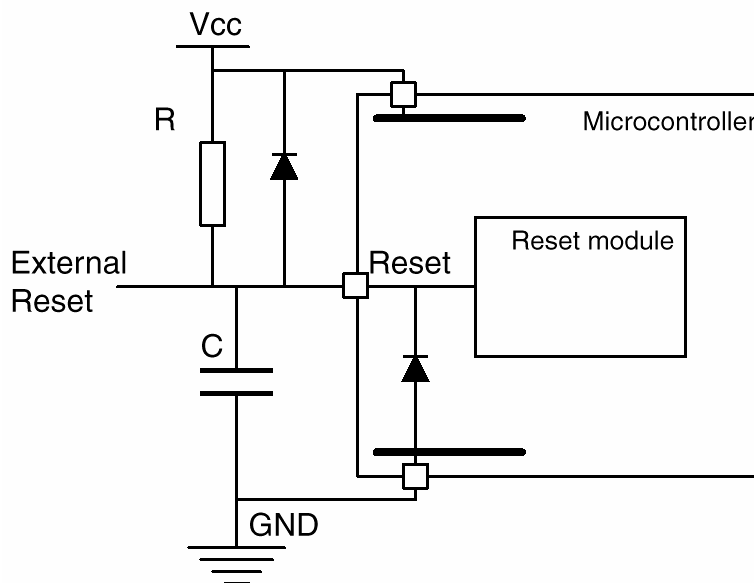

4 Connecting ISP lines

The In-System Programmable (ISP) lines are used for programming the Flash, EEPROM, Lock-bits and most Fuse-bits in all AVR's (except the ATtiny11 and ATtiny28). This feature makes it possible to program the AVR on the last stage of production of a target application board, reprogram if SW bugs are identified late in the process, or even update the AVR in the field if required. It is therefore highly recommended to always design the target application board so that the ISP connectors can be accessed in some way, - just in case.

Two standard connectors are provided by the Atmel ISP programmers; A 6 pin and a 10 pin connector. These are seen in Figure 4-1. In addition to the data lines (MOSI and MISO) and the bus clock (SCK), target voltage VTG, GND and RESET (RST) are provided through these connectors.

Figure 4-1. Standard ISP connectors on STK500, AVR ISP and STK200/STK300



Some ISP programmers are supplied by the target power supply. In this way they easily adapt to the correct voltage level of the target board. Other ISP programmers, like STK500, can alternatively power the target board via the VTG line. In that case it

is important that the power supply on the target is not switched on. Read the User Guide of the ISP programmer to find out what capabilities your programmer has and what kind of physical interface it has.

The ISP lines are on most devices located at the same pins as the Peripheral Serial Interface (SPI), or else on pins that can be used for other purposes. Consult the device data sheet to find out which lines are used for ISP. In case other devices than the AVR is connected to the ISP lines the programmer must be protected from any device, other than the AVR, that may try to drive the lines. This is especially important with the SPI bus, as it is similar to the ISP interface. Applying series resistors on the SPI lines, as depicted in Figure 4-2, is the easiest way of doing this. The AVR will never drive the SPI lines in a programming situation, since the AVR is held in RESET to enter programming mode – and RESET'ing the AVR tri-states all pins.

Figure 4-2. Connecting the SPI to the ISP interface.

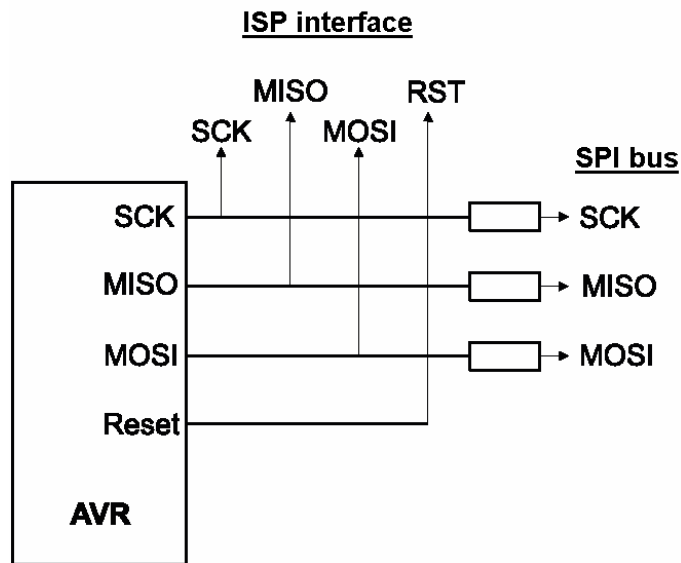

Multiple AVR's in a single application can share the same ISP interface to make it possible to program all of the devices through a minimal interface. However, the AVR devices will all respond to the ISP instructions if special design considerations are not made. If it is desired to have only one ISP interface on the target board, the ISP programming can be designed so that only one of the AVR devices is provided with a SPI clock at a time. All other SPI lines can then be shared. In this way all AVR's can be located "behind" the same protection resistors, since they all are held in RESET while the ISP reset line is activated. The gating of the ISP clock can be accomplished e.g. using jumpers. Alternatively, a solution is to have multiple ISP interfaces, one for each device, all protected as shown in Figure 4-2.

5 Using crystal and ceramic resonators

Most AVR MCUs can use different clock sources. The optional external clock sources are Clock, RC oscillator, crystal or ceramic resonator. The use of crystals and ceramic resonators are in some designs causing problems due to the fact that the use of these clock sources are not well understood. This section therefore treats the topic of using crystals and ceramic resonators in relation to AVR MCUs. The description

focus on features and parameters relevant for designing applications where crystals or ceramic resonators are used rather than trying to be a complete description of the theory related to the topic.

5.1 Selecting the clock source in the AVR

The clock source used by the AVR is selected through the fuses. Most ISP and parallel programmers can program the fuses that are related to selecting a clock source. The fuses are not erased when the AVR memory is erased and the fuses therefore only require to be programmed if the fuse settings should be altered. Programming the fuses each time the device is erased and reprogrammed is thus not necessary. The clock options that are relevant for this document are:

- “Ext. low-frequency crystal”
- “Ext. crystal oscillator”
- “Ext. ceramic resonator”

Several sub-settings relating to the start-up time of the AVR can be selected, but the 3 clock options mentioned are the fundamental settings that should be focused on. The clock options available can vary between AVR devices, - not all devices have the ability to run on various external oscillators. Check the datasheet for the relevant device to determine the clock options.

One should be aware that if selecting a different clock source than is actually applied, the AVR might not run since different oscillator circuits are activated internally in the AVR dependent on the selected clock option. Since the fuses are not cleared by a memory erase, it can cause problems if incorrect settings are chosen.

5.2 General about crystals and ceramic resonators

The typical type of crystal used for the AVR is the AT-cut parallel resonant crystal. The ceramic resonator is very similar to the AT-cut parallel resonant crystal, but is so to say a low cost, low quality version of the crystal. The ceramic resonator has a lower Q-value, which is both an advantage and disadvantage. Due to the lower Q-value the oscillator frequency of the ceramic resonator can more easily be “tuned” to a desired frequency, but is also more sensitive to temperature and load changes, causing undesired frequency variations. The advantage of the ceramic resonators is that it has a faster start-up than crystals.

In general there will not be distinguished between crystals and ceramic resonators in this section and the term “resonator” will thus refer to both devices.

Table 5-1. Technical differences between ceramic resonators and quartz crystal

	Ceramic resonator	Quartz crystal
Aging	±3000 ppm	± 10 ppm
Frequency tolerance	± 2000-5000 ppm	± 20 ppm
Freq. temperature characteristics	± 20-50 ppm/°C	± 0.5 ppm/°C
Frequency pullability	± 100-350 ppm/pF	± 15 ppm/pF
Oscillator rise time	0.01-0.5 ms	1-10 ms
Quality factor (Qm)	100-5000	10 ³ -5·10 ⁵

The parallel resonator is intended used in circuits, which contains reactive components, usual capacitors. Such circuits depend on the combination of the reactive components and the resonator to accomplish the phase shift necessary to start and maintain the oscillation at a given frequency. Basic oscillator circuits used for parallel resonators are illustrated in Figure 5-1. The part of the circuit above the dashed line, represent the oscillator circuit internally in the AVR.

Figure 5-1. Basic inverter circuits equivalent to the oscillator circuits in AVRs.

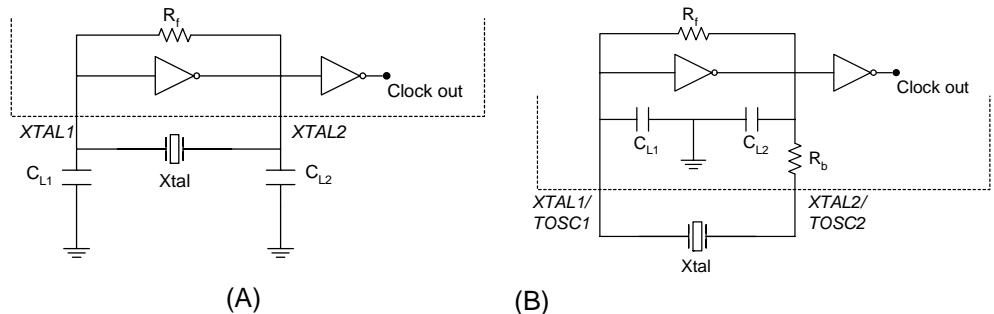

- Notes: (A) Oscillator circuit for crystals and ceramic resonators faster than 400kHz
 (B) Circuit for low frequency crystals (32.768kHz) (not on all AVRs)

Simplifying the description of the AVRs built-in oscillator circuits they can be understood as the inverter based oscillator circuits illustrated in Figure 5-1. The circuit used with resonators of frequencies *above* 400kHz is depicted in (A). When using this circuit, capacitive load must be applied externally. The oscillator circuit seen in (B) is the circuit used for low frequency crystals on some AVRs - to be more specific - optimized for 32.768kHz crystals. This circuit provides the capacitive load required by the crystal internally and further adds the resistor R_b to bias the crystal and limit the drive current into the crystal. The resistor R_f is, when using CMOS inverters, approximately 1Mohm, and provides a feedback to bias the inverter to operate it in its linear region. Consult data sheet for the relevant device to see if it has internal circuitry for low frequency crystals.

When using resonators with the AVR, it is necessary to apply (external) capacitors according to the requirements of the facilitated resonator. A parallel resonator will not be able to oscillate stable if the capacitive load applied is insufficient. If the capacitive load is too high the oscillation may have problems starting due to *drive level dependency* of the load. The trick is therefore to find an appropriate value for the capacitive load. The value to look for in the data sheet of the crystal is C_L , the recommended capacitive load of the resonator (viewed from the terminals of the resonator). The capacitive load, C_L , of the oscillator circuit, including stray capacitances and the capacitances of the XTAL pins of the AVR can be determined empirically or it can be estimated by Equation 5-1.

Equation 5-1.

$$C_L = \frac{C_{L1} \cdot C_{L2}}{C_{L1} + C_{L2}} + C_S$$

Where C_{L1} and C_{L2} referrers to the external capacitors seen in Figure 5-1 and C_S is the combined capacitive load of the XTAL pins of the AVR and stray capacitances of

the PCB. C_S can be estimated to be 5-10pF. If $C_{L1} = C_{L2}$ then the external capacitors can be determined by Equation 5-2:

Equation 5-2.

$$C_{L1} = C_{L2} = 2 \cdot (C_L - C_S)$$

5.3 Safety factor

To avoid overloading the crystal, so that it does not start up, the safety factor of the oscillator (including the specific crystal) should be verified. Overload is in general not causing start-up problems for ceramic resonators and therefore this section primarily applies to the use of crystals. To verify the *safety factor* of the oscillator, the *resonance load* (or *oscillation allowance*) must be determined. By inserting a resistor (R_Q) in series with the crystal (temporarily), as illustrated in Figure 5-2, the resonance load is determined.

Figure 5-2. R_Q in series with the crystal to determine the resonance load.

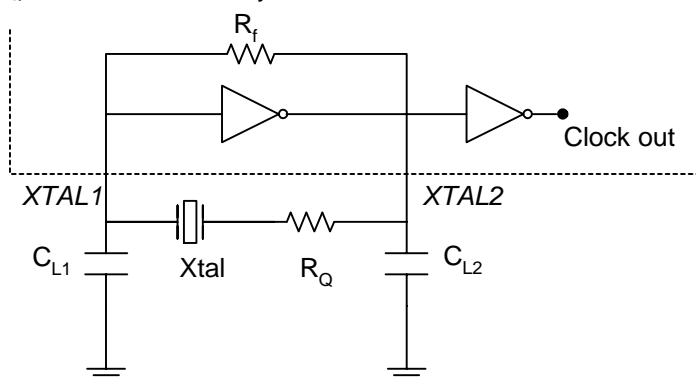

The way to do the test is to vary the external capacitors from a low capacitive load to a load where the oscillator stops oscillating. Make sure to mount the capacitors firmly, - avoid any kind of sockets.

Start the AVR having C_{L1} and C_{L2} as low as 1-2pF and verify that the oscillator is actually oscillating. If a current probe is available this can be used to investigate if the crystal is oscillating, otherwise a small test program toggling a pin on one of the I/O ports can be used to accomplish this. Increase C_{L1} and C_{L2} until the oscillator stops oscillating. Determine the safety factor by Equation 5-3. It is recommended to use a capacitive load that results in a Safety Factor of 3-5.

Equation 5-3.

$$\text{Safety Factor} = \frac{R_Q}{R_L}$$

Where the resonance load R_L is determined by Equation 5-4:

Equation 5-4.

$$R_L = R_1 \cdot \left(1 + \frac{C_0}{C_L} \right)^2$$

Where R_1 and C_0 are obtained from the datasheet of the resonator and C_L is the applied capacitive load calculated using Equation 5-1.

In the optimal test the curvature of the safety factor as a function of the applied capacitive load should be determined. If this is done one should be aware that it is not recommended to be at the top-point of the safety factor curvature, but rather at a point where the curve has started falling. Result of the test could look like the one seen in Figure 5-3.

Figure 5-3. Safety factor curvature for a given value of R_Q

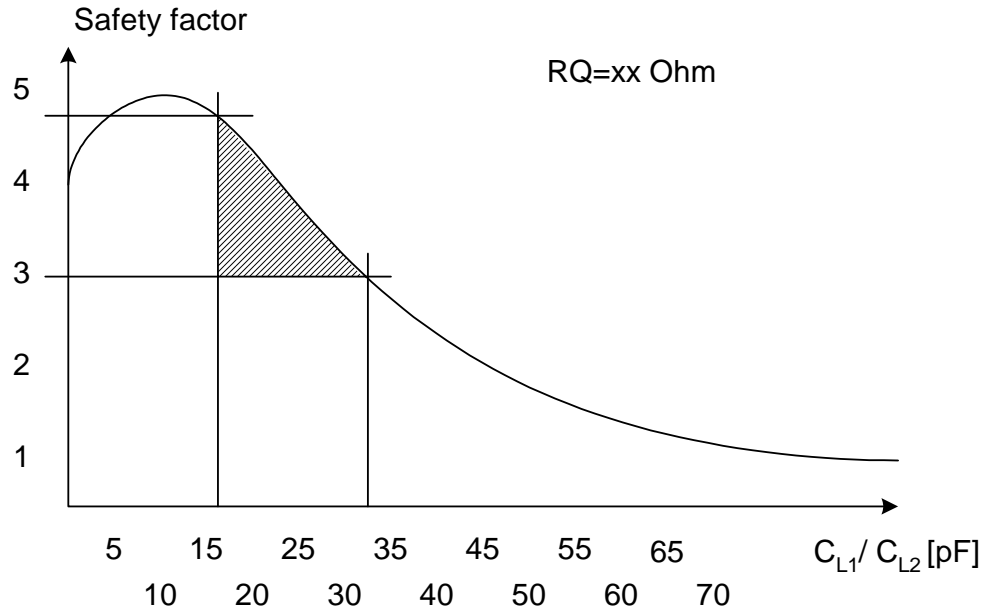

In the example in Figure 5-3 the hatched area indicates the safe area. In general the safety factor should be above 3 for the oscillator to be considered in the safe region of operation. Other factors should though be considered as well: The minimum required capacitive load, the recommended and the maximal drive level.

5.4 Recommended capacitor values

The recommendations here will work well in most applications, but there is no way to provide general values for the external capacitors that can be guarantee to work with all resonators.

When using the clock option “ext. crystal oscillator”, crystals with a nominal frequency from 400 kHz and up can be used. For these standard “high” frequency crystals the recommended capacitor value is in the range 22-33pF.

The clock option “ext. low frequency crystal” is intended for 32.768kHz crystals. When selecting this clock source the internal oscillator circuit might provide the required capacitive load. By programming the CKOPT Fuse, the user can enable internal capacitors on XTAL1 and XTAL2. The value of the internal capacitors is typical 20pF, but can vary. If using a 32.768kHz crystal that does not require more load than this, external capacitors can be left out. Otherwise external capacitive load must be added. In this case the capacitive load value, given by the manufacturer of the crystal, should

be used. Then the value of the external capacitors can be determined by Equation 2. The CKOPT Fuse should be unprogrammed when using external capacitors.

Please refer to the datasheet to assure whether the device has internal capacitors or not. Devices who support 1.8-5.5V operating voltages do not have internal capacitors (except Atmega162). Note that AT90S8535, Atmega163 and Atmega103 does not have the CKOPT-fuse, instead they have dedicated pins (TOSC1-TOSC2), to connect the 32.768 kHz watch crystal to.

Using the clock option that selects “ext. ceramic resonator” it is strongly recommended to consult the datasheet to determine the capacitors to apply. Always use the capacitive load recommended there since the resonant frequency of the ceramic resonators is very sensitive to capacitive load.

5.5 Pullability of the nominal frequency

The frequency of the resonator is depending on the capacitive load that is applied. Applying the capacitive load specified in the datasheet of the resonator will provide a frequency very close to the nominal frequency (intended oscillating frequency). If other capacitive loads are applied the oscillating frequency will change. The frequency will increase if the capacitive load is decreased and decrease if the load is increased. The frequency pullability - how far from the nominal frequency the resonant frequency can be forced by applying load - is depending on the type of resonator used or actually the Q-factor of the resonator. Typically crystals have a very high Q-factor, meaning that the pullability of the resonant frequency is relatively low. Some crystals have especially high Q-factors, e.g. 32.768kHz crystals since they are typically used for timing purposes, which require that the frequency is very exact. Ceramic resonators do not have high Q-factors and are therefore more sensitive to changes in capacitive load.

Regardless of the resonator type the resonant frequency can be pulled, by changing the capacitive load, but if a high capacitive load is applied it must be ensured that the oscillator can start in all conditions of operation. If the resonator is overloaded the oscillation can have problems starting, but once the oscillation has started it will seldom stop again due to overload. Touching the pins of a resonator that have not started oscillating, with a finger or an oscilloscope-probe, can be sufficient to start the oscillation and it can therefore be tricky to identify the overload problem.

To be able to determine the pullability of the resonator the “motional” capacitance of the resonator should be known. This value is not listed in all crystal datasheet and it is recommended to not intentionally try to pull the resonant frequency of the resonator unless understanding the theory behind this

5.6 Unbalanced external capacitors

In noisy environments the oscillator can be affected crucially by the noise. If the noise is strong enough the oscillator can “lock up” and stop oscillating. To make the oscillator less sensitive to noise the size of the capacitor at the high impedance input of the oscillator circuit, XTAL1, can be increased slightly. Increasing only one of the capacitors does not affect the total capacitive load much, but unbalanced capacitors can affect the resonant frequency to a higher degree than the change of the total capacitive load. However, unbalanced capacitive loads will affect the duty cycle of the oscillation and therefore one should in general not use unbalanced capacitive loads. This is especially critical if running the AVR close to its maximum speed limit.



5.7 RTC crystals

Many AVR devices have the possibility use asynchronous clocking of the built-in timer/counter. The counter can through this feature be used for real time functions. A 32.768KHz crystal should then be connected to the TOSCx pins of the AVR.

In some AVRs the internal oscillator circuit used with the real time counter provides a capacitive load of approximately 20pF, which should be appropriate for common 32.768KHz crystals. Refer to the data sheet for the relevant device for info about capacitors/size. External capacitors can be applied if the internal load is insufficient for the applied crystal.

5.8 PCB layout

Finally, the importance of the physical location of the resonator in relation to the AVR should be stressed. Always place the resonator as close to the AVR as possible and shield the resonator by surrounding it with a ground plane.

6 Example layout

Figure 6-1 (A-D) shows a schematic and PCB layout using a crystal oscillator for ATmega8515, decoupling digital supply from VCC is seen. Note the ground plane surrounding the crystal and the very short distance between the crystal and the ATmega8515.

Figure 6-1.

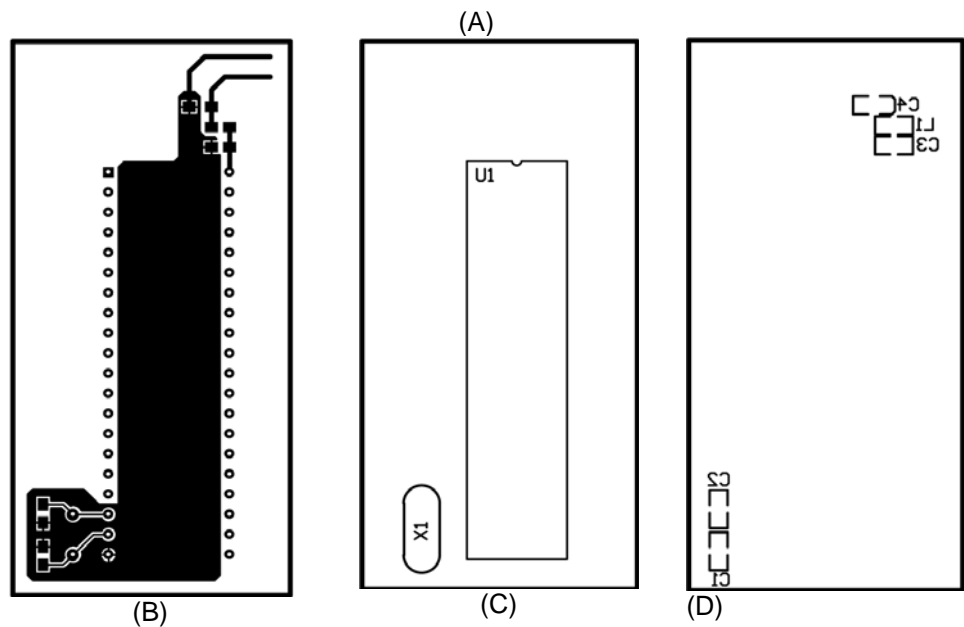
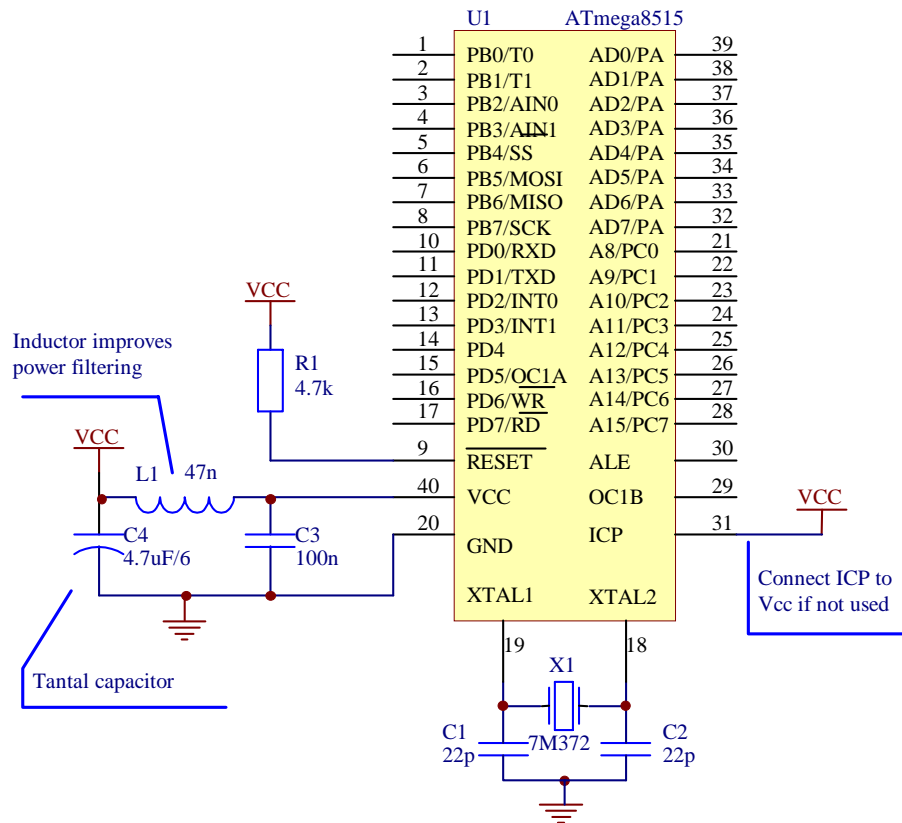

(A) basic schematic of required/recommended connections for AT90S8515. (B) Copper PCB layout. (C) and (D) top and bottom silk prints.



Atmel Corporation

2325 Orchard Parkway
San Jose, CA 95131, USA
Tel: 1(408) 441-0311
Fax: 1(408) 487-2600

Regional Headquarters

Europe

Atmel Sarl
Route des Arsenaux 41
Case Postale 80
CH-1705 Fribourg
Switzerland
Tel: (41) 26-426-5555
Fax: (41) 26-426-5500

Asia

Room 1219
Chinachem Golden Plaza
77 Mody Road Tsimshatsui
East Kowloon
Hong Kong
Tel: (852) 2721-9778
Fax: (852) 2722-1369

Japan

9F, Tonetsu Shinkawa Bldg.
1-24-8 Shinkawa
Chuo-ku, Tokyo 104-0033
Japan
Tel: (81) 3-3523-3551
Fax: (81) 3-3523-7581

Atmel Operations

Memory

2325 Orchard Parkway
San Jose, CA 95131, USA
Tel: 1(408) 441-0311
Fax: 1(408) 436-4314

Microcontrollers

2325 Orchard Parkway
San Jose, CA 95131, USA
Tel: 1(408) 441-0311
Fax: 1(408) 436-4314

La Chantrerie
BP 70602
44306 Nantes Cedex 3, France
Tel: (33) 2-40-18-18-18
Fax: (33) 2-40-18-19-60

ASIC/ASSP/Smart Cards

Zone Industrielle
13106 Rousset Cedex, France
Tel: (33) 4-42-53-60-00
Fax: (33) 4-42-53-60-01

1150 East Cheyenne Mtn. Blvd.
Colorado Springs, CO 80906, USA
Tel: 1(719) 576-3300
Fax: 1(719) 540-1759

Scottish Enterprise Technology Park
Maxwell Building
East Kilbride G75 0QR, Scotland
Tel: (44) 1355-803-000
Fax: (44) 1355-242-743

RF/Automotive

Theresienstrasse 2
Postfach 3535
74025 Heilbronn, Germany
Tel: (49) 71-31-67-0
Fax: (49) 71-31-67-2340

1150 East Cheyenne Mtn. Blvd.
Colorado Springs, CO 80906, USA
Tel: 1(719) 576-3300
Fax: 1(719) 540-1759

Biometrics/Imaging/Hi-Rel MPU/ High Speed Converters/RF Datacom

Avenue de Rochepleine
BP 123
38521 Saint-Egreve Cedex, France
Tel: (33) 4-76-58-30-00
Fax: (33) 4-76-58-34-80

Literature Requests
www.atmel.com/literature

Disclaimer: The information in this document is provided in connection with Atmel products. No license, express or implied, by estoppel or otherwise, to any intellectual property right is granted by this document or in connection with the sale of Atmel products. **EXCEPT AS SET FORTH IN ATMEL'S TERMS AND CONDITIONS OF SALE LOCATED ON ATMEL'S WEB SITE, ATMEL ASSUMES NO LIABILITY WHATSOEVER AND DISCLAIMS ANY EXPRESS, IMPLIED OR STATUTORY WARRANTY RELATING TO ITS PRODUCTS INCLUDING, BUT NOT LIMITED TO, THE IMPLIED WARRANTY OF MERCHANTABILITY, FITNESS FOR A PARTICULAR PURPOSE, OR NON-INFRINGEMENT. IN NO EVENT SHALL ATMEL BE LIABLE FOR ANY DIRECT, INDIRECT, CONSEQUENTIAL, PUNITIVE, SPECIAL OR INCIDENTAL DAMAGES (INCLUDING, WITHOUT LIMITATION, DAMAGES FOR LOSS OF PROFITS, BUSINESS INTERRUPTION, OR LOSS OF INFORMATION) ARISING OUT OF THE USE OR INABILITY TO USE THIS DOCUMENT, EVEN IF ATMEL HAS BEEN ADVISED OF THE POSSIBILITY OF SUCH DAMAGES.** Atmel makes no representations or warranties with respect to the accuracy or completeness of the contents of this document and reserves the right to make changes to specifications and product descriptions at any time without notice. Atmel does not make any commitment to update the information contained herein. Unless specifically provided otherwise, Atmel products are not suitable for, and shall not be used in, automotive applications. Atmel's products are not intended, authorized, or warranted for use as components in applications intended to support or sustain life.

© Atmel Corporation 2005. All rights reserved. Atmel®, logo and combinations thereof, Everywhere You Are®, AVR®, AVR Studio® and others, are the registered trademarks or trademarks of Atmel Corporation or its subsidiaries. Other terms and product names may be trademarks of others.